

Cycles du sommeil

De 2 ans à 6 ans.

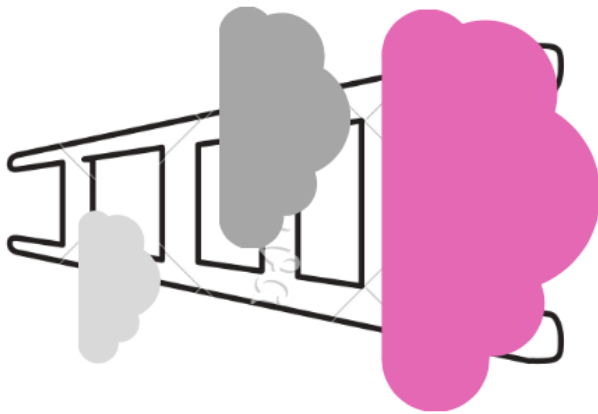

De 6 ans à adultes.

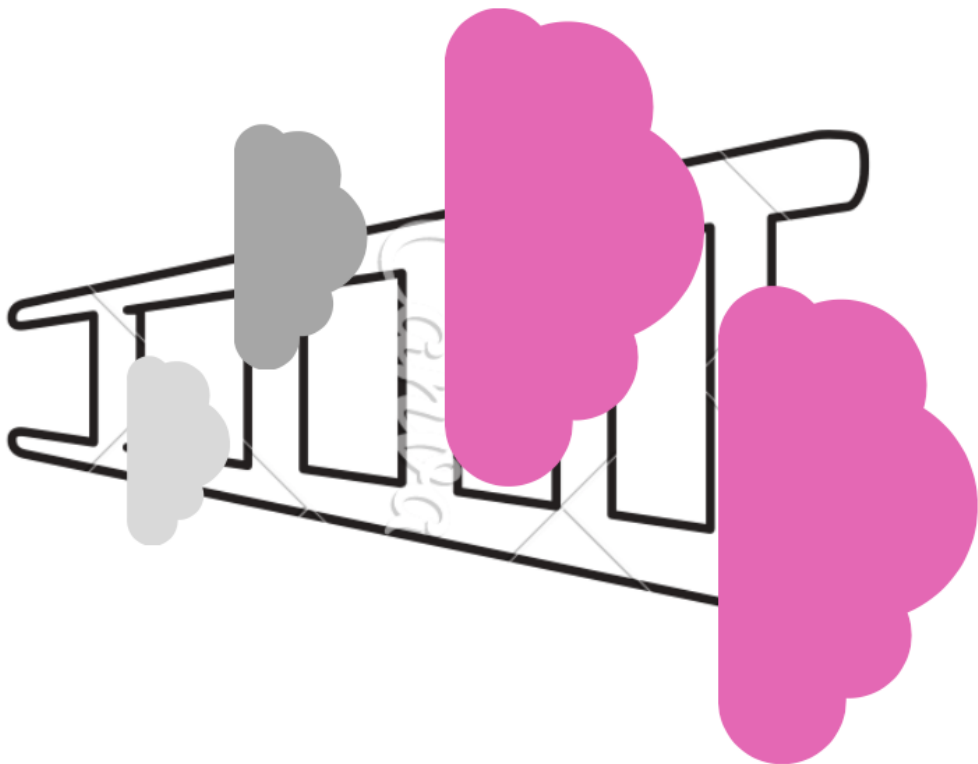
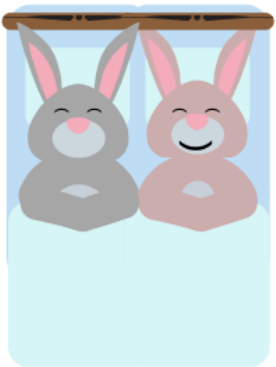

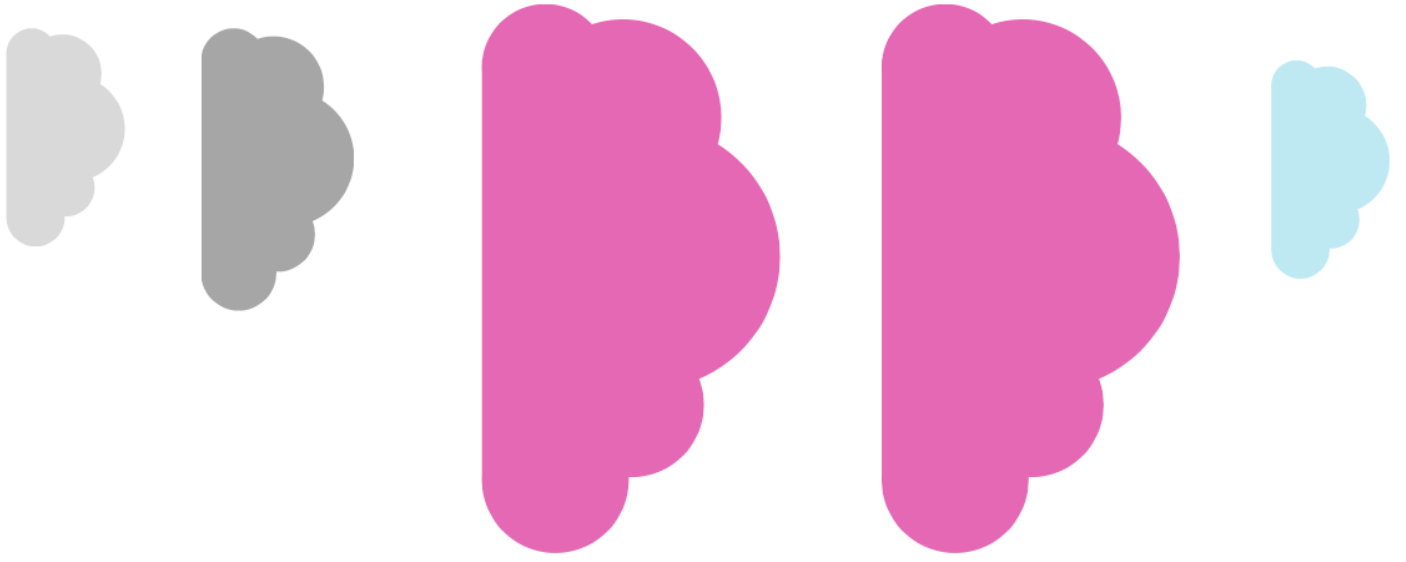
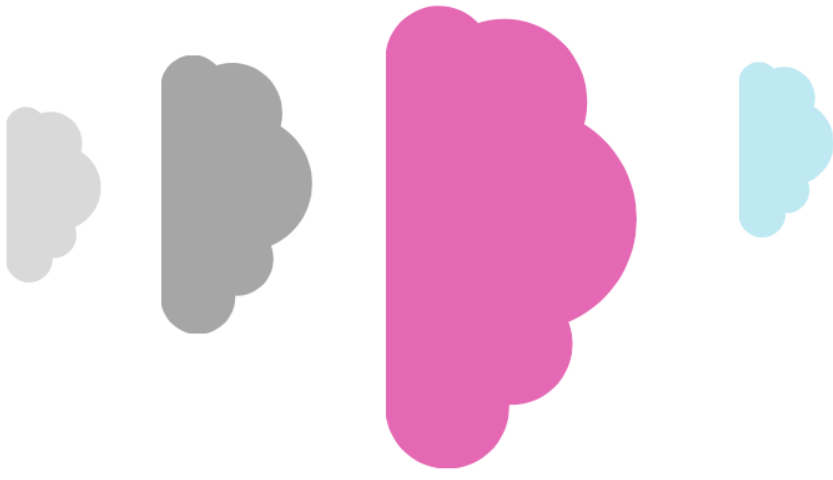

Cycles du sommeil

De 2 ans à 6 ans.

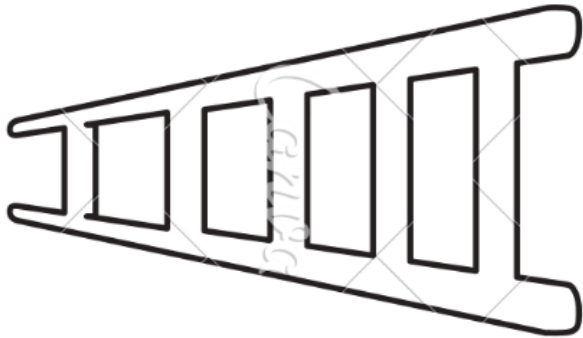

De 6 ans à adultes.

